



* 65 inch

* All images are for illustrative purposes only.

Commercial TV US665H (ASIA)

LG Smart Hotel TV with Effective Content Management

The US665H series supports clear Ultra HD and efficient content management with Pro:Centric solutions. In addition, the new webOS 5.0 for a wide variety of customer needs, provides customized content in an easier way.

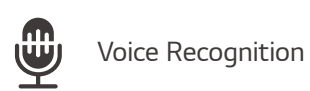

Pro:Centric HOTEL MANAGEMENT SOLUTION

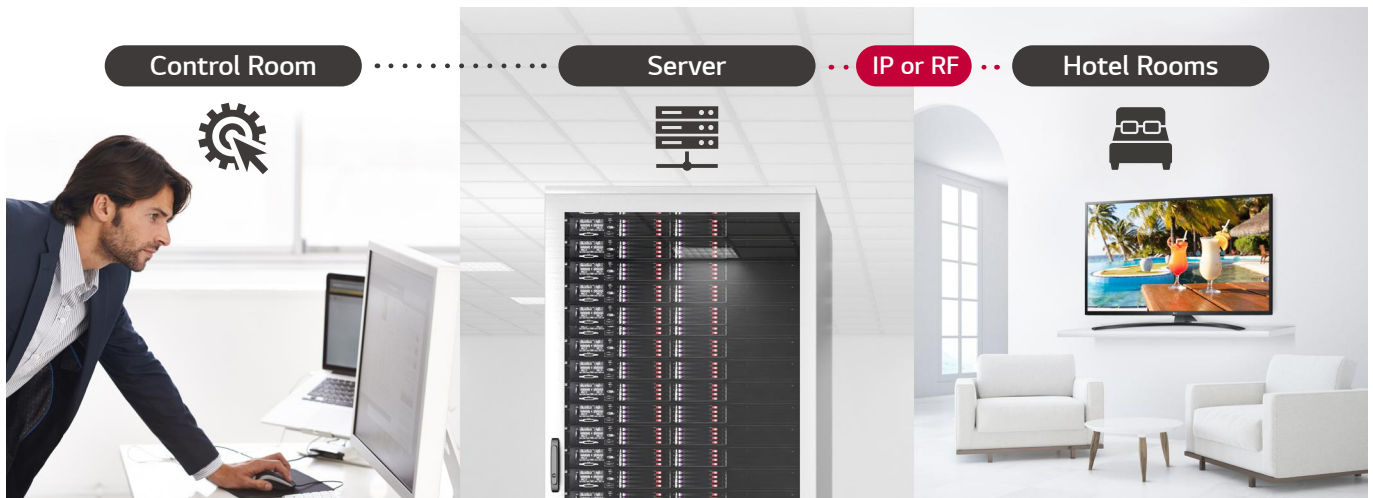

* Image shown is for illustrative purpose only.

Pro:Centric Direct

The hotel content management solution Pro:Centric Direct offers easy and simple editing tools, making it easy to perform service and IP network-based remote management. The Pro:Centric Direct solution enables users to easily edit their interface by providing a customized interface and efficiently manages TVs in the rooms. The current PCD version provides IoT-based in-room control as well as a voice control function through LG Natural Language Processing (NLP). These IoT and voice-related functions will be your starting point to prepare for the hotel rooms of the next generation through artificial intelligence.

* Some devices may have limited compatibility with the IoT and Voice Control function.
Please contact the LG sales team to verify the compatibility before ordering.

VALUE ADDED FEATURES

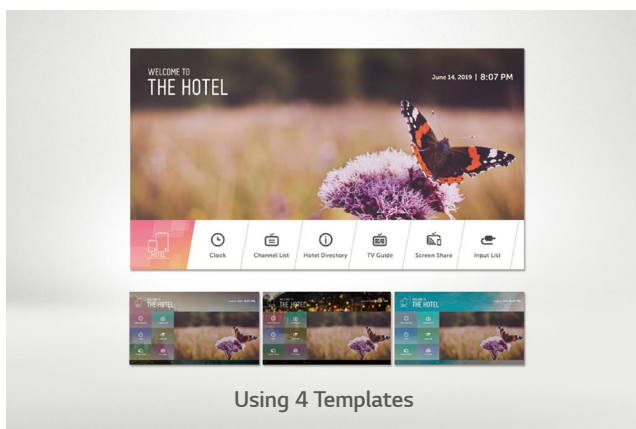

Using 4 Templates

* Image shown is for illustrative purpose only.

Quick Menu

Now LG provides the new Quick menu (ver. 4.0), making it easier and more user-friendly than the last version. The home menu solution has been upgraded in a big way with the addition of the new Hotel Promotional Video Creation Tool. Users can now also use Quick Manager for easy information distribution throughout the same network without a server or USB Cloning function, making this the perfect solution for Stand-Alone Usage Scenes.



* Image shown is for illustrative purpose only.

More Innovative LG webOS 5.0

Explore the latest LG Smart TV features. Newly added Mood Display & Gallery modes enable you to utilize the TV as a customized clock and a piece of artwork which harmonizes with your space and life.

* All images are for illustrative purposes only.

VALUE ADDED FEATURES

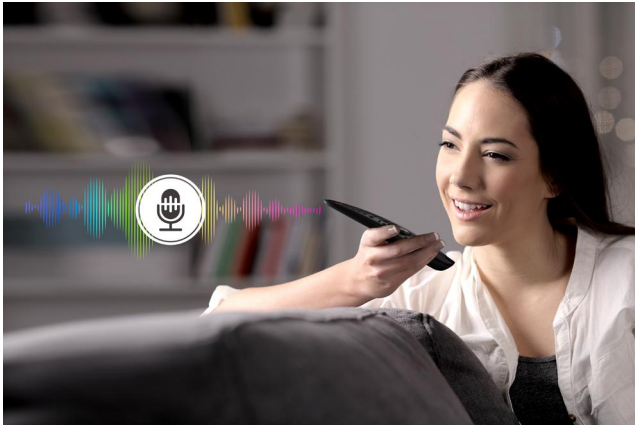

* Image shown is for illustrative purpose only.

Voice Recognition

From seamless interaction to consistent user experience, LG is going one step further to lead the commercial TV market by including voice recognition, allowing users to easily control LG TVs. Our stable and dependable solutions based on webOS and Pro:Centric Direct will significantly enhance the competitiveness of our products and services, helping you achieve a successful business in the future.

* Magic Motion Remote is required (sold separately)



* Image shown is for illustrative purpose only.

Soft AP

Software-enabled Access Point (Soft AP) is a "virtual" Wi-Fi feature that uses the TV as a wireless hotspot, enabling guests to connect their own devices to the Soft AP. It supports Bridge Mode, allowing administrators to manage in-room Soft AP information such as signal level, Soft AP passwords, etc.

* Soft AP should be setup in the installation menu after the TV is turned on.

* Smart Mirroring may not be operated at the same time.



* Image shown is for illustrative purpose only.

Hotel Mode (Public Display Mode)

You can control and set up the TV settings in business areas such as channel selection or volume level. It also enables you to restore default settings, as required, on the TVs.



* Image shown is for illustrative purpose only.

Multi DRM

Prevent illegal copying of content with widely used DRM (Digital Right Management) such as Pro:diom, Verimatrix and Secure Media.

* All images are for illustrative purposes only.

VALUE ADDED FEATURES



* Image shown is for illustrative purpose only.

USB Cloning

USB data cloning makes setting up multiple displays more efficient for optimal operation. Instead of setting up each display one by one, data can be copied to a USB for one display and can be sent to the other displays via USB plug-in.



* Image shown is for illustrative purpose only.

Remote Diagnostics

Save your expenses with the management of commercial TV with Remote Diagnostics. Remote Diagnostics quickly reports and detects error early in advance to prevent TVs from malfunctioning.



* Image shown is for illustrative purpose only.

Welcome Video / Screen

With the capability to display a image selected, LG Commercial TV allows for a greater variation in greeting messages in hotel rooms which make customers feel more welcomed and cared for.



* Image shown is for illustrative purpose only.

External Speaker Out

Enhance the entertainment experience with an additional speaker. Guests can listen and control the TV audio from anywhere in a hotel room.

* This feature may have a restriction depending on the installation environment.

* Additional speaker is not included with this product.

* All images are for illustrative purposes only.

PRODUCT INFORMATION

* 65 inch



US665H (ASIA)

Australia, New Zealand Only

Design	Stand Type	1 pole (Swivel, 55/40/43" / Fixed, 65")
	Front Color	Ceramic BK
Display	Inch	65" / 55" / 50" / 43"
	Resolution	3,840 × 2,160 (UHD)
Solution	Pro.Centric (Smart, Direct, V), Quick Menu	

DIMENSION

(unit: mm)

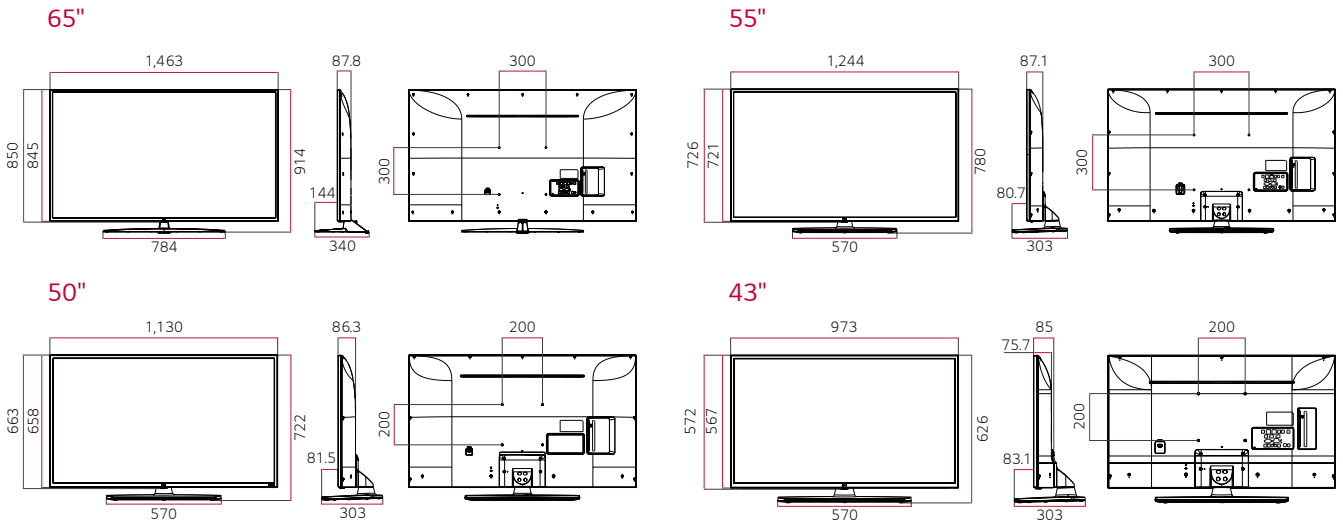

CONNECTIVITY

Rear

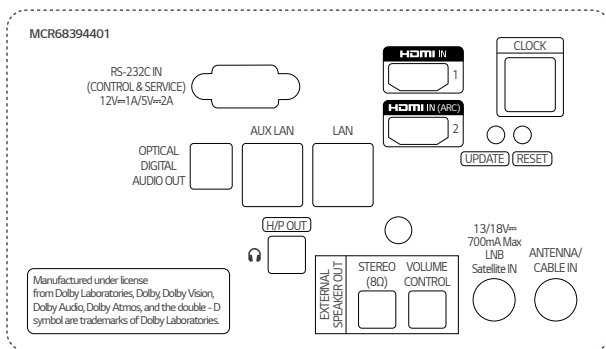

Side



* Dimensions & Jack Panels may differ from the above image, so please contact LG sales team to verify before ordering.



Download
LG C-Display+
Mobile App
Google Play Store

www.lg.com/global/business/information-display
www.youtube.com/c/LGCommercialDisplay
www.facebook.com/LGInformationDisplay
www.linkedin.com/company/lginformationdisplay
twitter.com/LG_ID_HQ

LG may make changes to specifications and product descriptions without notice. Copyright © 2020 LG Electronics Inc. All rights reserved. "LG Life's Good" is a registered trademark of LG Corp. The names of products and brands mentioned here may be the trademarks of their respective owners.

